



[MÉXICO]
**ANTES DE DEVOLVER EL
 PRODUCTO A LA TIENDA:**

**Comuníquese Con Servicio Al
 Cliente De Huffy. Nos Complace
 Ayudarlo Con Cualquier Parte
 O Problema De Ensamblado
 Que Pudiera Tener.**

Para obtener Servicio al cliente
 rápido, visite:

<http://www.huffybikes.com/>
 O LLAME AL TEL: 01800 1483 391
 (Mexico only)

Para comunicarse por correo electrónico:
servicio@huffymex.com

<http://www.huffybikes.com/home/globalcontact>

for current contact information
 para obtener la información de contacto actual
 pour les informations de contact actuelles

**For Assembly Help:
 Ayuda de la Asamblea:
 Aide à l'assemblage :**



[In the US and Canada]
PLEASE - BEFORE RETURNING TO STORE:

**Contact Huffy Customer Service. We
 are glad to assist you with any parts or
 assembly problems you might have!**

~
**VEUILLEZ NOTER : AVANT DE
 RETOURNER AU MAGASIN :**

**Communiquez avec le service à la clientèle
 de Huffy. Nous vous aiderons volontiers
 avec tout problème concernant les pièces
 ou le montage!**

For Fast Customer Service, go to:

Pour un Service à la clientèle rapide, visitez le :
<http://www.huffybikes.com/contact>

To Order Parts (US), go to:

Pour obtenir des pièces (CANADA), visitez le :
<http://www.huffybikes.com/parts>

OR TEL: 1 800 872 2453 (US only)

OU appelez le 1 800 872 2453 (CANADA seulement)

For email, go to <http://www.huffybikes.com/contact>

Pour communiquer par courriel, visitez le huffycanada@huffy.com



HUFFY
 © Copyright Huffy Corporation 2018

H-Tri_STOP-Global_010318_i0388

Date Code Label
 Here

Battery Ride-on Owner's Manual



**This manual contains important safety, assembly,
 operation and maintenance information.
 Please read and fully understand this manual before
 operation.**

Save this manual for future reference.

Always wear approved helmet and safety equipment when
 using this product.



**See back page for Customer Service Information
 Consulte el reverso para Servicio de Información al Cliente
 Voir pages verso pour des renseignements le service à la Clientèle**



Owner's Manual Index

Safety and Warnings	2-5
Assembly and Parts	6-13
Operation and Charging Battery	13-14
Maintenance and Service	15-16
• General Info, Battery Storage, Replacement and Disposal	
Troubleshooting	17-18
Warranty	19
 Contact Information	Back Cover

WARNING: CHOKING HAZARD:

- Small parts, adult assembly required.
- To reduce the risk of injury, adult supervision is required.
- Never use in roadways, near motor vehicles, on or near steep inclines or steps, swimming pools or other bodies of water; always wear shoes, and never allow more than one rider.
- The user must be **3-7 years**, and weigh no more than **65 lbs (30 kg)**.



IMPORTANT! Before using the unit for the first time the battery needs to be charged for at least **8 to 12 hours** - no more than **20 hours**. Only an adult who has read and understands the safety warnings should handle, charge or recharge of the battery (see **Operation** section).

This product meets ASTM F963 and CPSIA requirements for electric vehicles.

Limited Warranty - US

General:

Part or model specifications are subject to change without notice.

This Limited Warranty is the only warranty for the product. ALL WARRANTIES OTHER THAN STATED HEREIN ARE DISCLAIMED INCLUDING IMPLIED WARRANTIES OF MERCHANTABILITY AND FITNESS FOR A PARTICULAR PURPOSE, TO THE EXTENT ALLOWABLE BY APPLICABLE LAW. ALL LIABILITY FOR INCIDENTAL, PUNITIVE, SPECIAL, OR CONSEQUENTIAL DAMAGES ARE EXPRESSLY DISCLAIMED, TO THE EXTENT ALLOWABLE BY APPLICABLE LAW.

The only uses for this product are described in this manual.

Warranty registration is not required.

The Limited Warranty extends only to the original consumer and is not transferable to anyone else.

What does this Limited Warranty cover?

This Limited Warranty covers defects in workmanship and materials for all parts of the product except those indicated below as not warranted.

What must you do to keep the Limited Warranty in effect?

This Limited Warranty is effective only if:

- Product is completely and correctly assembled.
- Product is used under normal conditions for its intended purpose (see the following section for excluded activities).
- Product receives all necessary maintenance and adjustments.
- Product is used for general transportation and recreational use only.

What is not covered by this Limited Warranty?

This product is designed for recreational use only. This Limited Warranty does not cover normal wear and tear, normal maintenance items, or any damage, failure, or loss that is caused by improper assembly, maintenance, adjustment, storage, or use of the product. This Limited Warranty does not extend to future performance.

This Limited Warranty will be void if the product is ever:

- Used in any competitive sport
- Used for stunt riding, jumping, aerobatics or similar activity
- Modified in any way

- Modified with the addition of a motor
- Ridden by more than one person at a time
- Rented, sold, or given away
- Used in a manner contrary to the instructions and warnings in this Owner's Manual

What will The Manufacturer do?

Manufacturer's sole and exclusive obligation under this Limited Warranty is to repair and/or replace, at its sole option, any covered defect in workmanship or materials.

How do you get service?

Contact the Customer Service Department.

- See included list for Customer Contact information.

What rights do you have?

This Limited Warranty gives you specific legal rights. You may also have other rights which vary from State to State.

For how long does this Limited Warranty last?

- When used in this Limited Warranty, the phrase "for life" means for as long as the original consumer owns the product.
- Drive Battery - 90 days
- Electronics - 90 days
- All other Components - 6 months

BEFORE YOU CALL SUPPORT:

1. What is the model and date code?
2. When was the product purchased?
3. Has the product ever worked for a time or has never worked at all since purchase?
 - Yes, When did the product last operate correctly?
 - No, were the battery wires connected?
4. How long was the battery charged?
5. Is the charger plugged into the unit when you try to operate the product?
 - (The unit will not operate with charger plugged in)
6. Do any lights or sounds come on when you power the product on?
 - Yes, Does the lights and sounds go away when you press the drive switch?
7. When you press the drive switch, does an electric motor start?
 - Yes, Did you check that the correct drive wheel was installed?
 - Yes, Does the insert in the gearbox rotate?

 **WARNINGS**

Here are basic, common sense safe riding practices you should read aloud to your child and anyone who may use the vehicle.

It is the responsibility of the adult to educate the child, determine if they are fit to operate the vehicle, and supervise use.

- An adult must always supervise a child that is using the vehicle.
- Before using the vehicle the user must understand the controls and safety issues. They must also demonstrate the capability to handle the vehicle and operate its controls.
- Seat Models: Always sit in the seat when using the vehicle. Do not stand on side boards.
- This product contains small parts that are for adult assembly only. Keep small children away when assembling. Remove and dispose of all protective material and poly bags before assembly. Be sure to remove all packaging materials and parts from underneath the vehicle body.
- Always use the vehicle in a safe, secure environment with continuous adult supervision.
- Body parts such as hands, legs, hair and clothing can get caught in moving parts. Never place a body part near a moving part or wear loose clothing while using the vehicle. Always wear shoes when using vehicle.
- Use on flat, smooth paved surfaces only.
- Using the vehicle on or near streets, motor vehicle, drop-offs such as: steps, water (swimming pools), sloped surfaces, hills, wet areas, flammable vapors, in alleys, at night or in the dark could result in an accident.
- Do not use the vehicle in unsafe conditions such as snow, rain, loose dirt, mud sand or fine gravel. This may result in unexpected action such as tip over and skidding.
- Models with no brakes: Motor friction will gradually stop the unit.
- Do not use the vehicle in an unsafe manner. Examples include but are not limited to:
 - Pulling the vehicle with another vehicle or similar device.
 - Allowing more than one rider.
 - Pushing the vehicle.
 - Traveling at an unsafe speed.
- There are additional hazards of using the vehicle in areas other than private grounds.
- Not to be used in traffic.
- The vehicle shall be used with caution since skill is required to avoid falls or collisions.
- Do not overload the vehicle.
- Do not tow anything behind the vehicle.
- Do not drive up steep slopes.
- Do not drive into fixed objects, which may cause the wheels to spin, causing the motor to overheat.
- Do not drive in very hot weather, components may overheat.
- Do not allow water or other liquids to come in contact with the battery or other electric components.
- Do not tamper with the electrical system. Doing so may create a short, causing the fuse to trip or other damage including fire.
- Do not stand on or in vehicle while moving.
- Child should always wear an approved helmet when using this product.
- If equipped, child should always use properly and securely attached Seat Belt.
- Only use authorised replacement parts.
- Operators shall adhere to all recommendations and instructions as well as comply with all laws and ordinances.

Helmet Warning Information

⚠️ WARNING: ALWAYS WEAR YOUR HELMET WHEN RIDING THIS PRODUCT!

- Helmet should sit level on your head and low on your forehead. Exposed forehead can result in serious injury.
- Adjust the strap sliders below the ear on both sides.
- Buckle the chin strap. Adjust strap until it is snug.
- No more than two fingers should fit between the strap and your chin.
- A proper fitting helmet should be comfortable and not rock forward/backward or side to side.

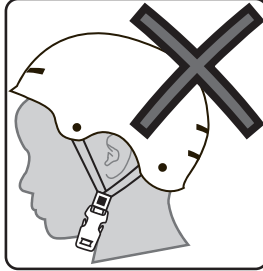
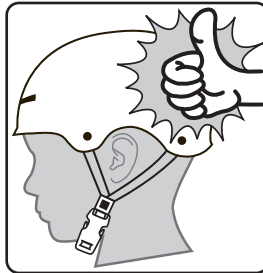

Radio Frequency Information (charger/adaptor/controller)

⚠️ WARNING: Changes or modifications to this unit not expressly approved by the party responsible for compliance could void the user's authority to operate the equipment.

This device complies with Part 15 of the FCC Rules. Operation is subject to the following two conditions:

(1) this device may not cause harmful interference, and (2) this device must accept any interference received, including interference that may cause undesired operation.

NOTE: This equipment has been tested and found to comply with the limits for a Class B digital device, pursuant to Part 15 of the FCC Rules. These limits are designed to provide reasonable protection against harmful interference in a residential installation. This equipment generates, uses and can radiate

radio frequency energy and, if not installed and used in accordance with the instructions, may cause harmful interference to radio communications.

However, there is no guarantee that interference will not occur in a particular installation. If this equipment does cause harmful interference to radio or television reception, which can be determined by turning the equipment off and on, the user is encouraged to try to correct the interference by one or more of the following measures:

- Reorient or relocate the receiving antenna.
- Increase the separation between the equipment and receiver.
- Connect the equipment into an outlet on a circuit different from that to which the receiver is connected.
- Consult the dealer or an experienced radio/TV technician for help.

Troubleshooting Guide

The following are examples of potential problems. Completely read through this manual and the troubleshooting guide table before calling. If you still need help resolving the problem please contact Customer Service.

NOTE: Vehicle should be turned off and fully charged before doing troubleshooting.

Problem	Possible Cause	Solution
Vehicle does not run when switch is activated	Battery wires not connected or are loose	Connect battery wires according to assembly instructions, Check that the battery connectors are firmly plugged into each other. If wires are loose around the motor call Customer Service.
	Battery low on power	Recharge battery (see Battery: Recharge interval and time)
	Battery Charger still plugged in	Unplug Battery Charger from unit and wall in
	Thermal fuse has tripped	Let Fuse reset
	Battery is dead	Replace battery (see Battery: Replacement and Disposal)
	Electrical system or motor is damaged	Call Customer Service.
Vehicle does not run very long or runs sluggishly	Battery is undercharged.	Check that the battery connectors are firmly plugged into each other when recharging (see Battery: Recharge interval and Time)
	Battery is old and cannot be fully charged	Replace battery (see Battery: Replacement and Disposal)
	Vehicle is overloaded	Reduce weight on vehicle (see user requirements and Safety Warnings)
	Vehicle is being used in harsh conditions	Avoid using vehicle in harsh conditions (see User Requirements and Safety Warnings)
Vehicle makes loud noise when in use	Chain is dry (on chain drive models)	Lubricate chain with light oil.
Loud grinding or clicking noises coming from motor or gear box	Motor or gears are damaged	Call Customer Service.
	Drive Wheel is partially engaged	Check drive wheel - to motor engagement.
Battery will not recharge	Battery connector or adapter connector is loose	Check that the battery connectors are firmly plugged into each other.
	Charger is not working	Check that the battery charger is plugged into a working wall outlet.
	Battery is dead	Replace battery.
Charger feels warm when recharging	This is normal and not a cause for concern	If excessively hot, unplug and replace.

Drive Battery Replacement and Disposal

The drive battery will eventually lose the ability to hold a charge. Depending on the amount of use, and varying conditions, the battery should operate for one to three years. Follow these steps to replace and dispose the battery:

1. Remove left side Lower Engine Cover (A) and 3 screws (B).
2. Carefully lift the battery.
 - Depending on the condition of the battery (i.e.: leakage) you may want to wear protective rubber gloves before removal.
 - Do not lift the battery by its connectors or cables.
3. Disconnect the battery connectors.
4. Place the dead battery in a plastic bag.

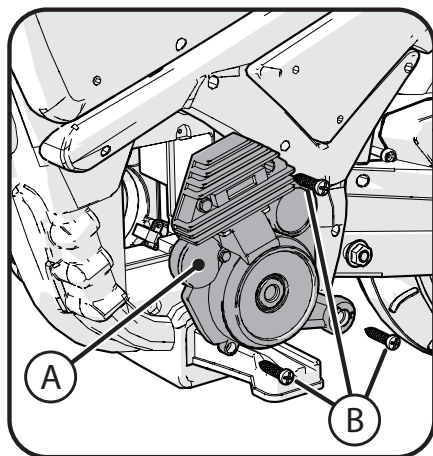

IMPORTANT!

- The sealed lead-acid battery must be recycled or disposed of in an environmentally sound manner.
- Do not dispose of battery in a fire. The battery may explode or leak acid.
- Do not dispose of the battery in household trash. The incineration, land filling or mixing of sealed lead-acid batteries with household trash is prohibited by law.
- Return an exhausted battery to a federal or state approved lead-acid battery recycler, such as a local seller of automotive batteries (check local battery disposal regulations).

NOTE: Replacement batteries are available at most battery supply stores. Document battery size and type (found on battery).

5. Install replacement battery and reconnect the connectors.
6. Replace Engine Cover and 3 screws.

Battery storage

The drive battery should be charged when depleted, or if not used regularly, once a month. Failure to charge the battery as directed will cause permanent damage to the battery and will void the warranty.

Follow these guidelines if the battery is removed:

- Do not store battery in extreme hot or cold temperatures.
- Wipe the battery clean with a dry cloth prior to storage. Wash cloth separate from other clothes.

! BATTERY & CHARGER WARNINGS:



The following safety hazards may result in serious injury or death to the user of the vehicle:

- Battery Charger for Indoor use only.
- Use of a battery or charger other than the supplied rechargeable battery and charger may cause a fire or explosion. Only use the supplied rechargeable battery (or lead-acid or lithium suitable replacement) and charger with the vehicle.
- Using the rechargeable battery and charger for any other product may result in overheating, fire or explosion. Never use the rechargeable battery and charger with another product.
- Explosive gases are created during charging. Charge the battery in a well ventilated area. Do not charge the battery near heat or flammable materials.
- Contact between the positive and negative terminals may result in fire or explosion. Avoid direct contact between the terminals. Picking up the battery by the wires or charger can cause damage to the battery and may result in a fire. Always pick up the battery by its case or handles.
- Battery must be handled by adults only. Liquids on the battery may cause fire or electric shock. Always keep all liquids away from the battery and keep the battery dry.
 - Contact or exposure to battery leakage (lead acid) may cause serious injury. If contact or exposure occurs immediately call your physician. If the chemical is on the skin or in the eyes, flush with cool water for 15 minutes. If the chemical was swallowed, immediately give the person water or milk. Do not give water or milk if the patient is vomiting or has a decreased level of alertness. Do not induce vomiting.
- Battery Posts, terminals and related accessories contain lead and lead compounds (acid), chemicals known to cause cancer, reproductive harm and are toxic and corrosive. Never open the battery.
- Tampering or modifying the electric circuit system may cause a shock, fire or explosion and permanently damage the system. Exposed wiring and circuitry in the charger may cause electric shock. Always keep the charger housing closed.
- Non-rechargeable batteries are not to be recharged
- Batteries are to be inserted with the correct polarity
- The supply terminals are not to be short-circuited
- Batteries are only to be charged by adults or by children at least 8 years old
- The battery chargers used with the toy are to be regularly examined for damage to the cord, plug, enclosure and other parts, and in the event of such damage, they must not be used until the damage has been repaired.

NOTE: It is not necessary to remove the battery from the vehicle for charging.

IMPORTANT! Before using the unit for the first time the battery needs to be charged for **8 to 12 hours - never longer than 20 hours**. Only an adult who has read and understands the safety warnings should handle, charge or recharge of the battery.

Parts View

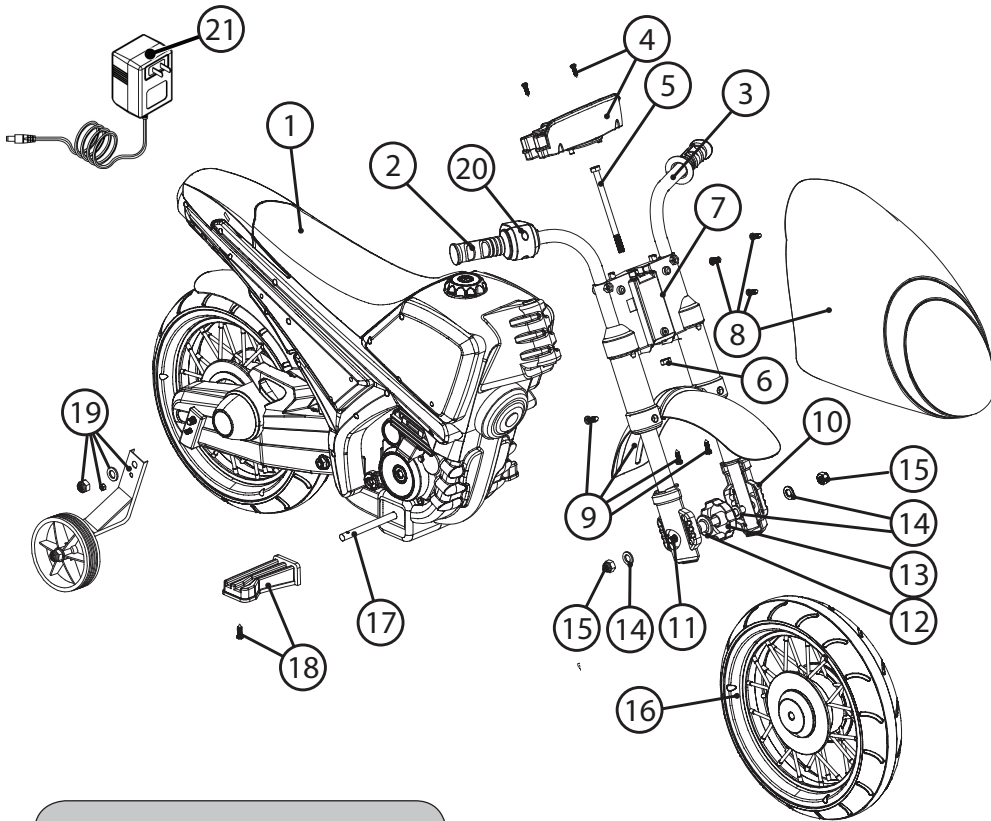

NOTE: All features, components and accessories are not included on all models.

Maintenance Repair and Service

GENERAL: The vehicle should be checked for damage, missing or badly worn parts before each use. If any part of the product does not operate properly – discontinue use.

- Check the tightness of the fasteners before each use. Replace any fasteners that are damaged.
- Inspect the product frequently. Failure to inspect the product and to make repairs or adjustments, as necessary, can result in injury to the rider or to others. Make sure all parts are correctly assembled and adjusted as written in this manual and any “Special Instructions”.
- Immediately replace any damaged, missing, or badly worn parts.
- Make sure all fasteners are correctly tightened as written in this manual and any “Special Instructions”. Parts that are not tight enough can be lost or operate poorly. Over tightened parts can be damaged. Make sure any replacement fasteners are the correct size and type.

- Check the tightness of the wheels:

NOTE: If the drive wheel is not tight, it will not engage the gears and the vehicle will not run.

- Ensure the battery bracket is securely in place before use.
- Store the vehicle indoors. Keep it away from sources of heat, such as stoves and heaters.
- Keep the product clean and free of dirt, dust and water. This will prolong the useful life of the product.
- Clean the vehicle with a soft, dry cloth. To restore shine to plastic parts, use a non-wax furniture polish. Do not use automotive wax, abrasive cleaners or wash the vehicle with soap and water.

NOTE: If the instructions in this manual or any “Special Instructions” are not sufficient for you, please contact customer service.

CAUTION: Self-locking nuts and other self-locking devices may lose their effectiveness when re-used.

Charging the Drive Battery:



IMPORTANT! Before using the unit for the first time the battery needs to be charged for at least **8 to 12** hours - no more than **20** hours. Once battery is depleted, recharge for **8 to 12** hours - no more than **20** hours.

IMPORTANT!

Check the drive battery and charger (supply cord, connector) for wear and damage before charging. Do not charge the battery if damage has occurred. Only replace with the same type and voltage rechargeable battery and charger supplied by the manufacturer.

- Only use the rechargeable battery (or equivalent replacement) and charger supplied with your vehicle.
- Always turn power off and charge battery after riding.
- The drive battery should be charged when depleted, or if not used regularly, once a month. Failure to charge the battery as directed will cause permanent damage to the battery and will void the warranty.

STEPS:

1. Turn power switch OFF.
2. Locate Charging Port **(A)**.
3. Plug Charger plug into unit Charging Port.
4. Plug Charger into Wall outlet **(B)**.
5. When battery is fully charged, unplug charger from the wall outlet and disconnect from charger port.

NOTE: The charger may feel warm during the charging. If excessively hot, unplug and replace.

NOTE: This product has charging protection: When charging, all functions are turned OFF.

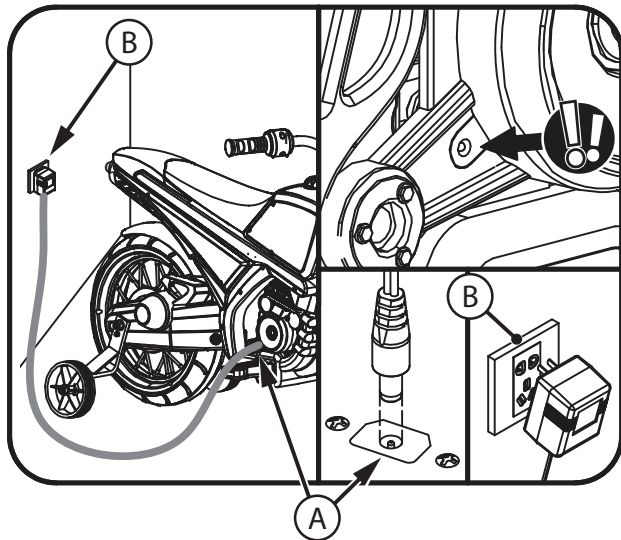

Parts List

#	Description	#	Description
1	Vehicle body	12	Short Axle Bushing
2	Right Handlebar	13	Long Axle Bushing
3	Left Handlebar	14	M10 Axle Washer (x4)
4	Instrument Panel	15	M8 Locknut (x2)
	• M4 Attach Screws (x2)	16	Front Wheel
5	M8 Fork Bolt	17	Foot Peg Shaft
6	M8 Fork Attach Nut	18	Foot Pegs Set (left and right)
7	Fork Brace		• M4x16 Screw (x2)
8	Windshield/Plaque	19	Training Wheel Set
	• M4 Attach Screws (x3)		• M8 Locknut (x2)
9	Mudguard		• M10 Washer (x2)
	• M4 Attach Screws (x3)		• M5 Nut (x2)
10	Lower Fork Cover Set	20	Power Switch Assy.
11	Front Axle	21	Charger

Tools Needed

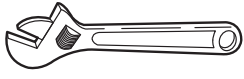

Adjustable Wrench

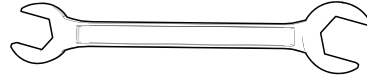

Open-end Wrenches

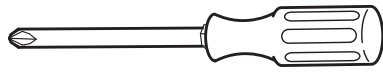

Phillips Screwdriver

Wiring and Battery

Wiring Diagram

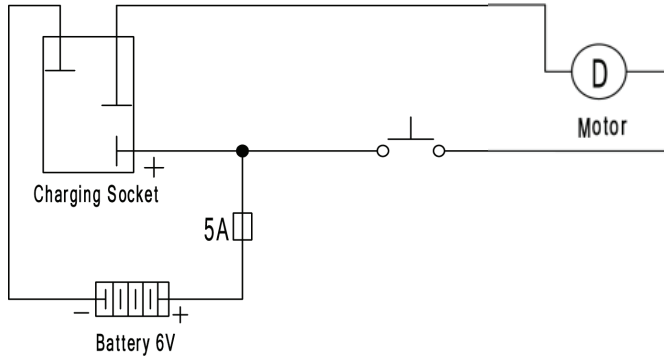

Battery and Fuse

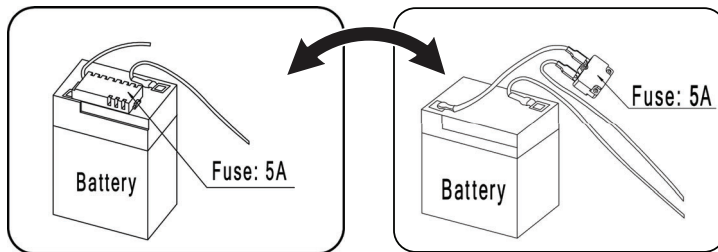

Assembly the Instrument Panel:

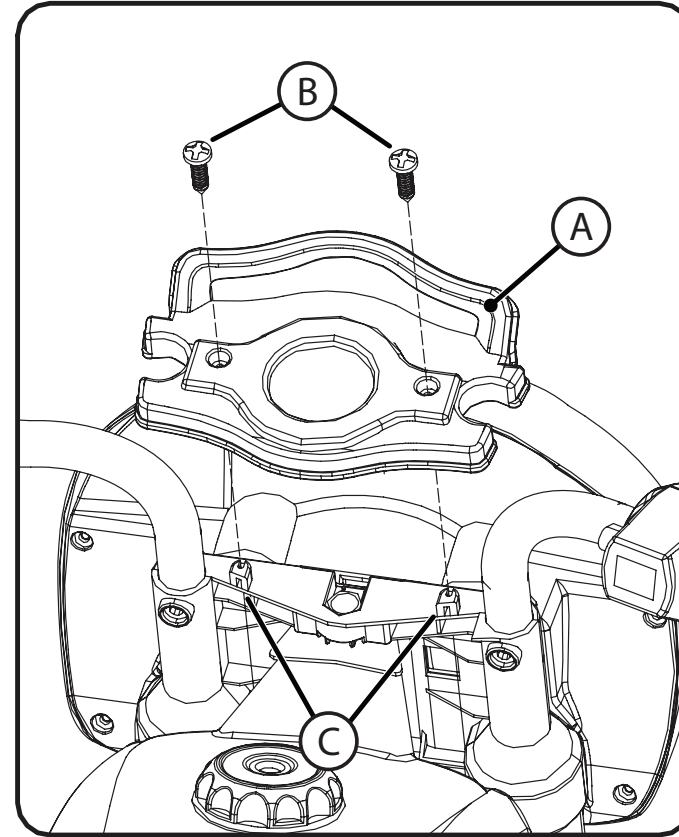

Installing the Instrument Panel:

1. Fit the Instrument Panel **(A)** down between handlebars fully as shown so that mounting holes line up.
2. Install two Screws **(B)** into Fork Mount **(C)** as shown. Tighten securely. Do not over-tighten.

How to Operate the Motorcycle

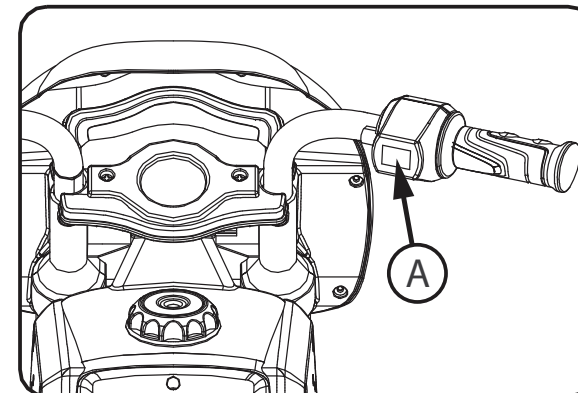

1. Press the Power button **(A)** to go FORWARD.
 - Release the Power button to STOP.

Attach the Front Fork:

STEPS:

1. Attach Fork by fitting Fork Mount (A) over frame Body (B) as shown - lining up top and bottom Fork Mount holes with Body.
2. Insert Pivot Bolt (D) down through Fork and Body so that Bolt head sits in recess.
3. Install Steering Nut (C) from bottom.
4. Using a wrench or socket, tighten Steering Nut (C) securely. Do not over-tighten.

CAUTION:

Make sure Fork turns easily back and forth from left stop to right stop.

ATTACH CONNECTORS:

1. Firmly connect the Fork Connector (E) to the Motor Connector (F) as shown.

CAUTION:

Make sure fork turns fully left or right without pinching or damaging wires or connectors.

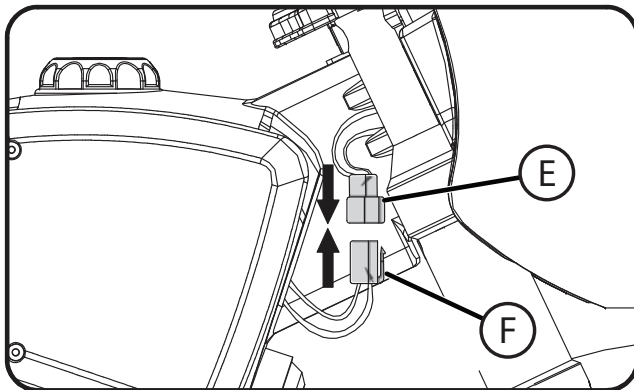
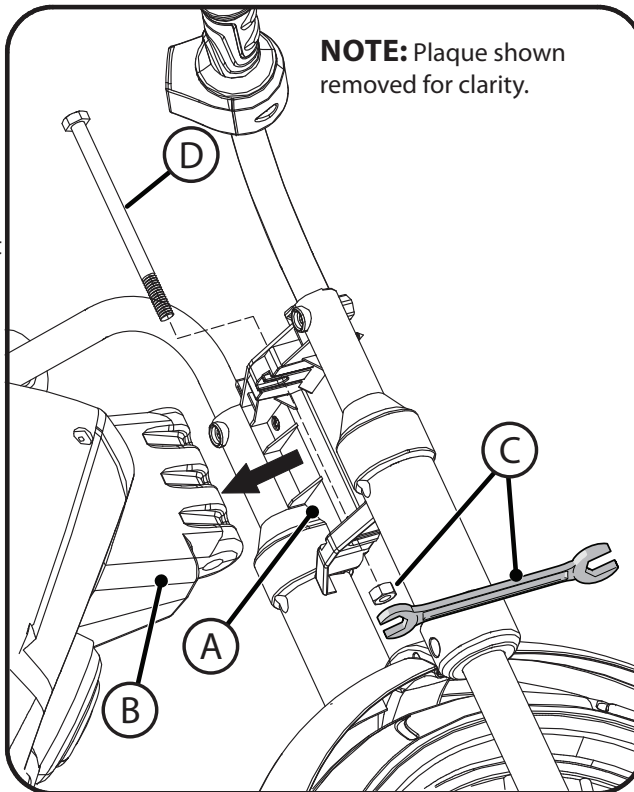

Install Training Wheels and Foot Pegs:

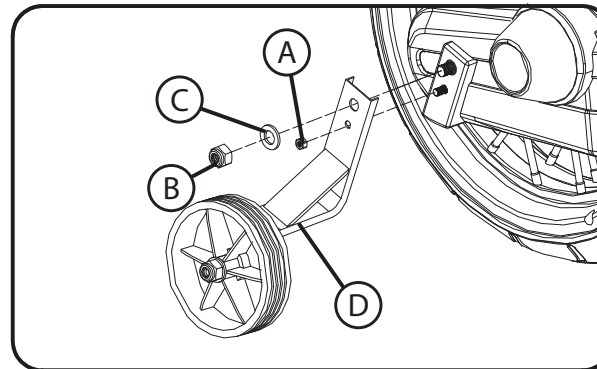

Installing the Training Wheels:

1. Remove the two nuts (A) (B) and one washer (C) from the side of the rear Axle.
2. Install the training wheel (D), washer (C) and both nuts (A) (B). Tighten securely.
3. Repeat for opposite side.

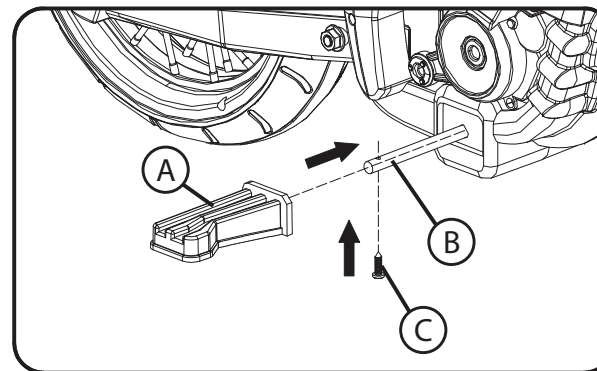

Installing the Foot Pegs:

NOTE: Foot Peg Shaft passes through the Body.

1. Install Peg (A) on Shaft (B) in direction shown. Attach with screw (C) as shown. Tighten securely.
2. Repeat for opposite side.

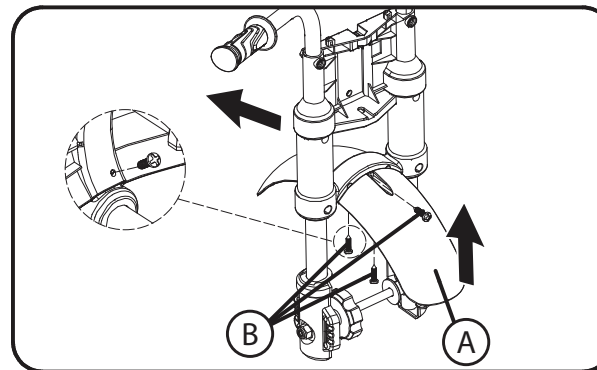

Installing the Mudguard:

1. Install Mudguard (A) in direction shown.
2. Attach with Screws (B) as shown.
3. Tighten Screws securely.

WARNING: DO NOT REMOVE TRAINING WHEELS. This vehicle is not intended to be used without training wheels and serious injury may result.

Install the Front Tire:

NOTE: Directions are shown looking at front of Fork Assembly.

1. Start by inserting Axle (A), Locknut (B) and Washer (C) through Left Fork Leg (D) just far enough to place one Washer (C) and SHORT Bushing (E) in position.
2. Position Wheel with Disc Brake (F) on LEFT side onto Axle end - making sure washer and short bushing stay in place.
3. Slide Axle through Wheel just far enough to place LONG bushing (G) and Washer (C) in place as shown.
4. Slide Axle fully through the right fork leg.
5. Install Washer (C) and Locknut (H). Tighten both Nuts securely so that threads are fully through the Locknuts.

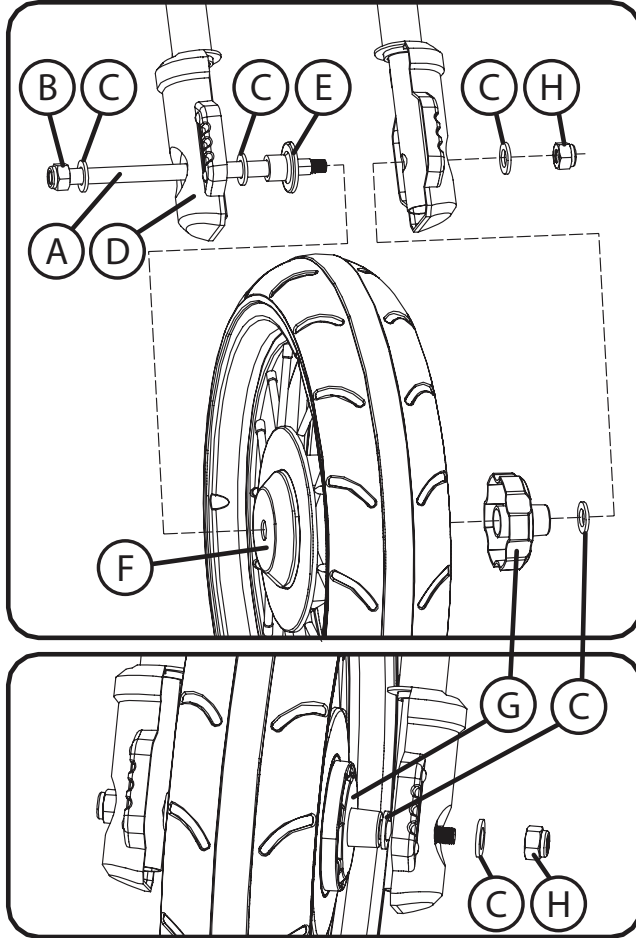

CAUTION:

Make sure Wheel spins freely and easily. If Wheel is too tight, it can damage the drive motor.

Install the Front Plaque:

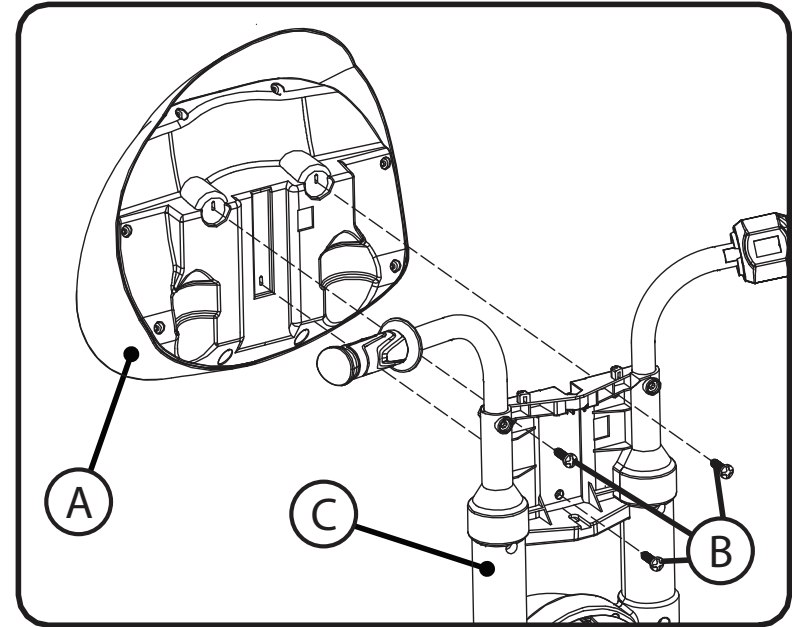

NOTE: Plaque styles may vary.

Install the Plaque:

1. Position the Plaque (A) in front of the fork and align the 3 attach points as shown.
2. Install 3 Screws (B) through Fork Brace (C) and into Plaque attach points as shown.
3. Tighten Screws evenly and securely. Do not over-tighten.